

---

## RAD-TOLERANT CLASS-V REGULATING PULSE WIDTH MODULATOR

---

### FEATURES

- QML-V Qualified, SMD 5962-89511
- Rad-Tolerant: 30 kRad (Si) TID <sup>(1)</sup>
- 8-V to 35-V Operation
- 5.1-V Buried Zener Reference Trimmed to  $\pm 0.75\%$
- 100-Hz to 400-kHz Oscillator Range
- Separate Oscillator Sync Terminal
- Adjustable Deadtime Control
- Internal Soft Start
- Pulse-by-Pulse Shutdown
- Input Undervoltage Lockout With Hysteresis
- Latching PWM to Prevent Multiple Pulses
- Dual Source/Sink Output Drivers
- Low Cross Conduction Output Stage
- Tighter Reference Specifications

(1) Radiation tolerance is a typical value based upon initial device qualification with dose rate = 10 mrad/sec. Radiation Lot Acceptance Testing is available - contact factory for details.

### DESCRIPTION

The UC1525B pulse width modulator integrated circuit is designed to offer improved performance and lowered external parts count when used in designing all types of switching power supplies. The on-chip 5.1-V buried zener reference is trimmed to  $\pm 0.75\%$ , and the input common-mode range of the error amplifier includes the reference voltage, eliminating external resistors. A sync input to the oscillator allows multiple units to be slaved or a single unit to be synchronized to an external system clock. A single resistor between the CT and the discharge terminals provide a wide range of dead-time adjustment. These devices also feature built-in soft-start circuitry with only an external timing capacitor required. A shutdown terminal controls both the soft-start circuitry and the output stages, providing instantaneous turn off through the PWM latch with pulsed shutdown, as well as soft-start recycle with longer shutdown commands. These functions are also controlled by an undervoltage lockout which keeps the outputs off and the soft-start capacitor discharged for sub-normal input voltages. This lockout circuitry includes approximately 500 mV of hysteresis for jitter-free operation. Another feature of these PWM circuits is a latch following the comparator. Once a PWM pulse has been terminated for any reason, the outputs remain off for the duration of the period. The latch is reset with each clock pulse. The output stages are totem-pole designs capable of sourcing or sinking in excess of 200 mA. The UC1525B output stage features NOR logic, giving a LOW output for an OFF state.



Please be aware that an important notice concerning availability, standard warranty, and use in critical applications of Texas Instruments semiconductor products and disclaimers thereto appears at the end of this data sheet.

**BLOCK DIAGRAM**

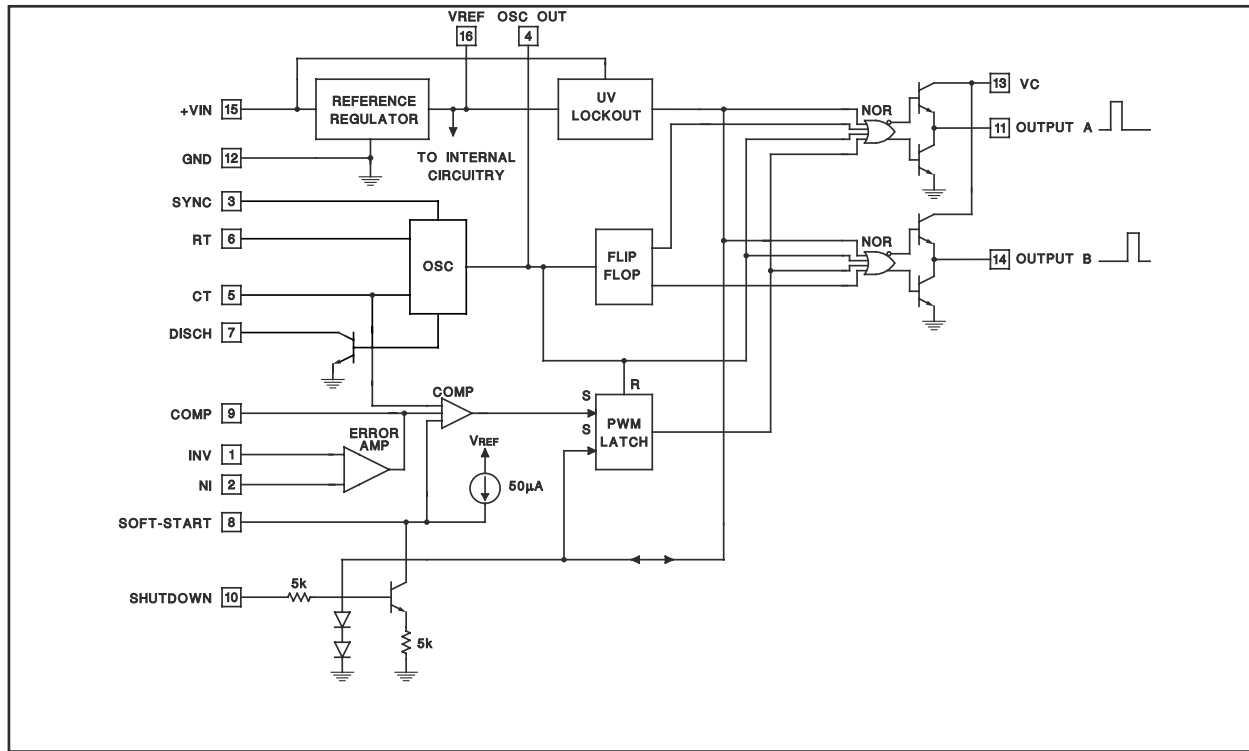

This device has limited built-in ESD protection. The leads should be shorted together or the device placed in conductive foam during storage or handling to prevent electrostatic damage to the MOS gates.

**ORDERING INFORMATION<sup>(1)</sup>**

T <sub>A</sub>	PACKAGE <sup>(2)</sup>	ORDERABLE PART NUMBER	TOP-SIDE MARKING
-55°C to 125°C	FK	5962-8951106V2A	UC1525BFK-SP

- (1) For the most current package and ordering information, see the Package Option Addendum at the end of this document, or see the TI web site at [www.ti.com](http://www.ti.com).
- (2) Package drawings, thermal data, and symbolization are available at [www.ti.com/packaging](http://www.ti.com/packaging).

**ABSOLUTE MAXIMUM RATINGS<sup>(1)(2)</sup>**

over operating free-air temperature range (unless otherwise noted)

+V <sub>IN</sub>	Supply voltage		40 V
V <sub>C</sub>	Collector supply voltage		40 V
	Logic inputs		–0.3 V to 5.5 V
V <sub>I</sub>	Analog inputs		–0.3 V to V <sub>IN</sub>
I <sub>O</sub>	Output current, source or sink		500 mA
	Reference output current		50 mA
	Oscillator charging current		5 mA
P <sub>D</sub>	Power dissipation	T <sub>A</sub> = 25°C	1000 mW
		T <sub>C</sub> = 25°C	2000 mW
T <sub>J</sub>	Operating junction temperature		–55°C to 150°C
T <sub>stg</sub>	Storage temperature range		–65°C to 150°C
T <sub>lead</sub>	Lead temperature (soldering, 10 seconds)		300°C

- (1) Stresses beyond those listed under *absolute maximum ratings* may cause permanent damage to the device. These are stress ratings only, and functional operation of the device at these or any other conditions beyond those indicated under *recommended operating conditions* is not implied. Exposure to absolute-maximum-rated conditions for extended periods may affect device reliability.
- (2) All voltages are with respect to ground. Currents are positive into, negative out of the specified terminal.

**RECOMMENDED OPERATING CONDITIONS<sup>(1)</sup>**

over operating free-air temperature range (unless otherwise noted)

		MIN	MAX	UNIT
+V <sub>IN</sub>	Input voltage	8	35	V
V <sub>C</sub>	Collector supply voltage	4.5	35	V
	Sink/source load current (steady state)	0	100	mA
	Sink/source load current (peak)	0	400	mA
	Reference load current	0	20	mA
	Oscillator frequency range	0.1	400	kHz
	Oscillator timing resistor	2	150	kΩ
	Oscillator timing capacitor	0.001	0.1	μF
	Dead time resistor range	0	500	Ω

- (1) Range over which the device is functional and parameter limits are specified.

## CONNECTION DIAGRAM

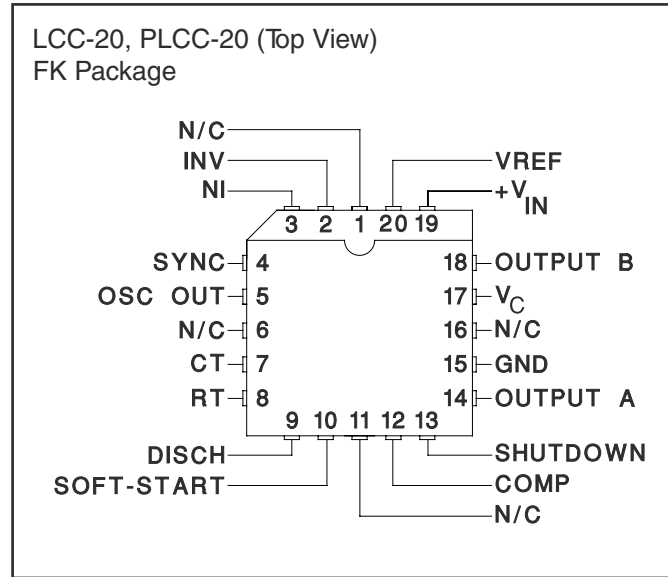

## ELECTRICAL CHARACTERISTICS

$V_{IN} = 20\text{ V}$ ,  $T_A = T_J = -55^\circ\text{C}$  to  $125^\circ\text{C}$  (unless otherwise noted)

PARAMETER	TEST CONDITIONS	MIN	TYP	MAX	UNIT
<b>Reference Section</b>					
Output voltage	$T_J = 25^\circ\text{C}$	5.062	5.10	5.138	V
Line regulation	$V_{IN} = 8\text{ V}$ to $35\text{ V}$		5	10	mV
Load regulation	$I_L = 0\text{ mA}$ to $20\text{ mA}$		7	15	mV
Temperature stability <sup>(1)</sup>	Over operating range		10	50	mV
Total output variation	Over line, load, and temperature	5.036		5.164	V
Short-circuit current	$V_{REF} = 0\text{ V}$ , $T_J = 25^\circ\text{C}$		80	100	mA
Output noise voltage <sup>(1)</sup>	$10\text{ Hz} \leq f \leq 10\text{ kHz}$ , $T_J = 25^\circ\text{C}$		40	200	$\mu\text{Vrms}$
<b>Oscillator Section</b>					
Initial accuracy <sup>(2)</sup>	$T_J = 25^\circ\text{C}$		$\pm 2$	$\pm 6$	%
Voltage stability <sup>(2)</sup>	$V_{IN} = 8\text{ V}$ to $35\text{ V}$		$\pm 0.3$	$\pm 1$	%
Temperature stability <sup>(1)(2)</sup>	Over operating range		$\pm 3$	$\pm 6$	%
Minimum frequency	$R_T = 200\text{ k}\Omega$ , $C_T = 0.1\text{ }\mu\text{F}$			120	Hz
Maximum frequency	$R_T = 2\text{ k}\Omega$ , $C_T = 470\text{ pF}$	400			kHz
Current mirror	$I_{RT} = 2\text{ mA}$	1.7	2.	2.2	mA
Clock amplitude <sup>(2)</sup>		3	3.5		V
Clock width <sup>(2)</sup>	$T_J = 25^\circ\text{C}$	0.3	0.5	1	$\mu\text{s}$
Sync threshold		1.2	2	2.8	V
Sync input current	Sync = $3.5\text{ V}$		1	2.5	mA

(1) Parameters ensured by design and/or characterization, if not production tested.

(2) Tested at  $f_{osc} = 40\text{ kHz}$  ( $R_T = 3.6\text{ k}\Omega$ ,  $C_T = 0.01\text{ }\mu\text{F}$ ,  $R_D = 0\text{ }\Omega$ ).  
Approximate oscillator frequency is defined by:  $f = 1/(C_T (0.7 \times R_T + 3R_D))$ .

**ELECTRICAL CHARACTERISTICS (continued)**
 $V_{IN} = 20\text{ V}$ ,  $T_A = T_J = -55^\circ\text{C}$  to  $125^\circ\text{C}$  (unless otherwise noted)

PARAMETER	TEST CONDITIONS	MIN	TYP	MAX	UNIT
<b>Error Amplifier Section (<math>V_{CM} = 5.1\text{ V}</math>)</b>					
Input offset voltage			0.5	5	mV
Input bias current			1	10	$\mu\text{A}$
Input offset current				1	$\mu\text{A}$
DC open loop gain	$R_L \geq 10\text{ M}\Omega$	60	75		dB
Gain-bandwidth product <sup>(3)</sup>	$A_V = 0\text{ dB}$ , $T_J = 25^\circ\text{C}$	1	2		MHz
Output low level			0.2	0.5	V
Output high level		3.8	5.6		V
Common mode rejection	$V_{CM} = 1.5\text{ V}$ to $5.2\text{ V}$	60	75		dB
Supply voltage rejection	$V_{IN} = 8\text{ V}$ to $35\text{ V}$	50	60		dB
<b>PWM Comparator</b>					
Minimum duty cycle				0	%
Maximum duty cycle <sup>(4)</sup>		45	49		%
Input threshold <sup>(4)</sup>	Zero duty cycle	0.7	0.9		V
Input threshold <sup>(4)</sup>	Maximum duty cycle		3.3	3.6	V
Input bias current			0.05		$\mu\text{A}$
<b>Shutdown Section</b>					
Soft start current	$V_{SHUTDOWN} = 0\text{ V}$ , $V_{SOFTSTART} = 0\text{ V}$	25	50	80	$\mu\text{A}$
Soft start low level	$V_{SHUTDOWN} = 2.5\text{ V}$		0.4	0.7	V
Shutdown threshold	To outputs, $V_{SOFTSTART} = 5.1\text{ V}$ , $T_J = 25^\circ\text{C}$	0.6	0.8	1	V
Shutdown input current	$V_{SHUTDOWN} = 2.5\text{ V}$		0.4	1	mA
Shutdown delay <sup>(3)</sup>	$V_{SHUTDOWN} = 2.5\text{ V}$ , $T_J = 25^\circ\text{C}$		0.2	0.5	$\mu\text{s}$
<b>Output Drivers (Each Output) (<math>V_C = 20\text{ V}</math>)</b>					
Output low level	$I_{SINK} = 20\text{ mA}$		0.2	0.4	V
	$I_{SINK} = 100\text{ mA}$		1	2	
Output high level	$I_{SOURCE} = 20\text{ mA}$	18	19		V
	$I_{SOURCE} = 100\text{ mA}$	17	18		
Undervoltage lockout	$V_{COMP}$ and $V_{SOFTSTART} = \text{High}$	6	7	8	V
Collector leakage	$V_C = 35\text{ V}$			200	$\mu\text{A}$
Rise time <sup>(3)</sup>	$C_L = 1\text{ nF}$ , $T_J = 25^\circ\text{C}$		100	600	ns
Fall time <sup>(3)</sup>	$C_L = 1\text{ nF}$ , $T_J = 25^\circ\text{C}$		50	300	ns
Cross conduction charge	Per cycle, $T_J = 25^\circ\text{C}$		30		nC
<b>Total Standby Current</b>					
Supply current	$V_{IN} = 35\text{ V}$		14	20	mA

(3) Parameters ensured by design and/or characterization, if not production tested.

(4) Tested at  $f_{osc} = 40\text{ kHz}$  ( $R_T = 3.6\text{ k}\Omega$ ,  $C_T = 0.01\text{ }\mu\text{F}$ ,  $R_D = 0\text{ }\Omega$ ).  
Approximate oscillator frequency is defined by:  $f = 1/(C_T (0.7 \times R_T + 3R_D))$ .

PRINCIPLES OF OPERATION AND TYPICAL CHARACTERISTICS

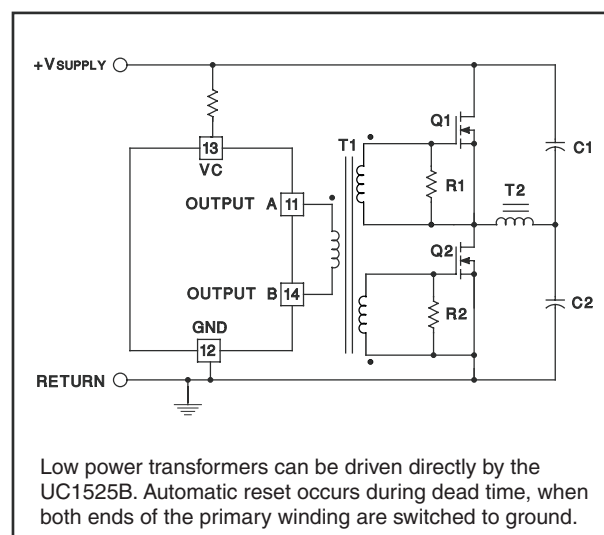
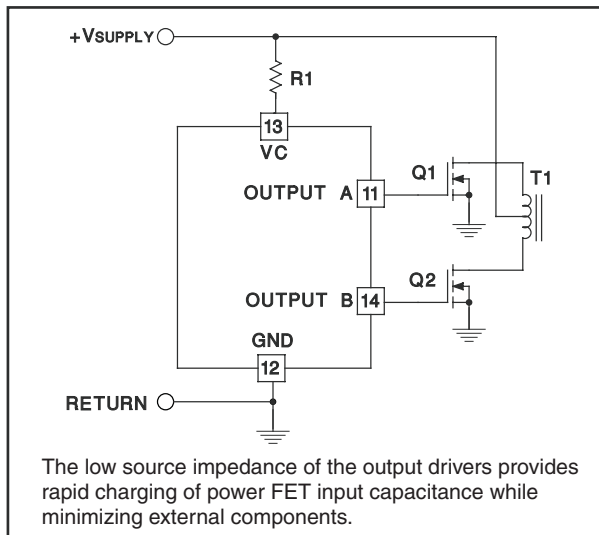
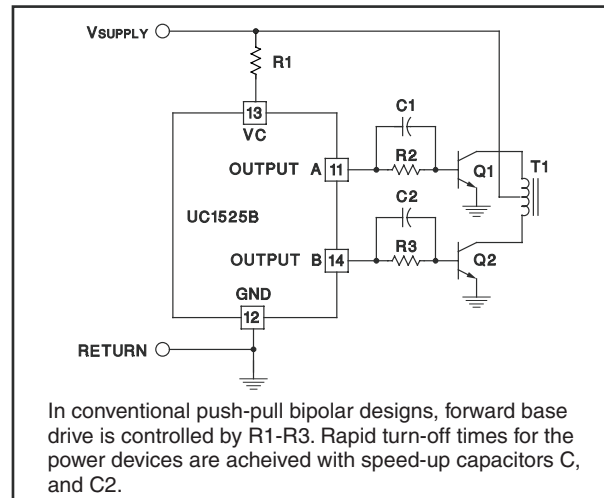
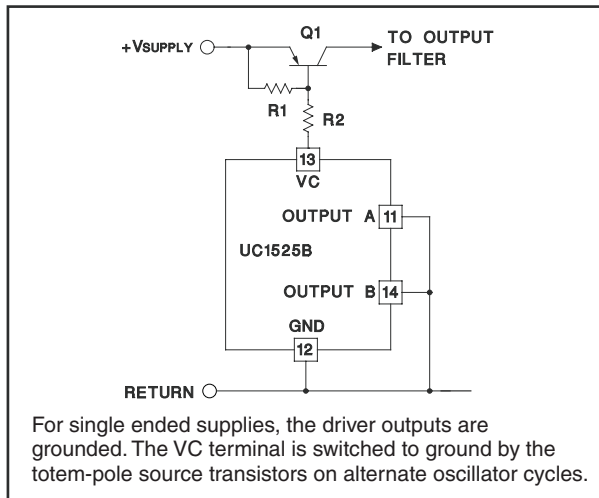
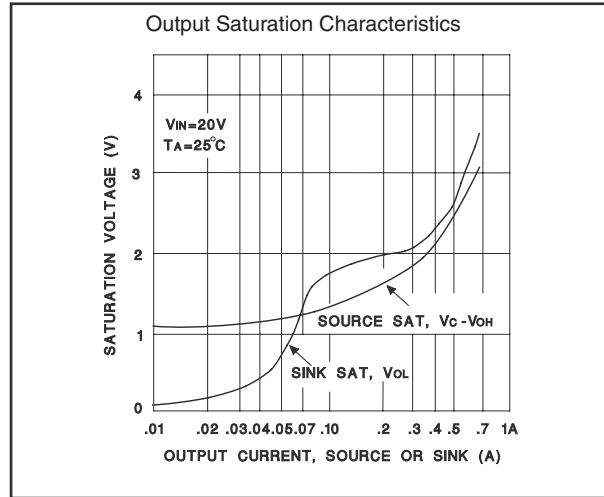
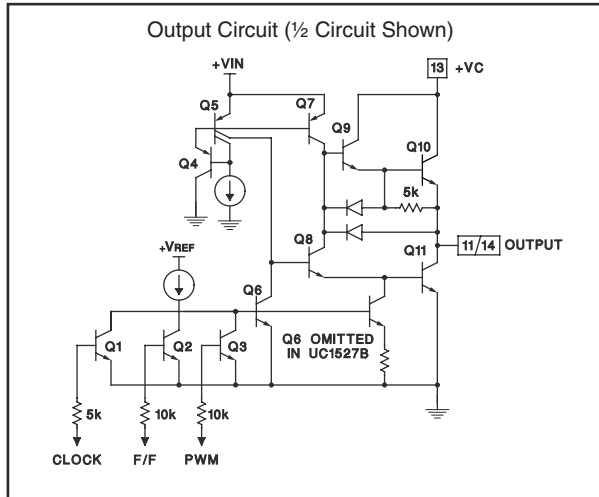

### PRINCIPLES OF OPERATION AND TYPICAL CHARACTERISTICS (continued)

Since both the compensation and soft-start terminals (Pins 9 and 8) have current source pullups, either can readily accept a pulldown signal, which only has to sink a maximum of 100  $\mu\text{A}$  to turn off the outputs. This is subject to the added requirement of discharging whatever external capacitance may be attached to these pins.

An alternate approach is the use of the shutdown circuitry of Pin 10, which has been improved to enhance the available shutdown options. Activating this circuit by applying a positive signal on Pin 10 performs two functions: the PWM latch is immediately set providing the fastest turn-off signal to the external soft-start capacitor. If the shutdown command is short, the PWM signal is terminated without significant discharge of the soft-start capacitor, thus, allowing, for example, a convenient implementation of pulse-by-pulse current limiting. Holding Pin 10 high for a longer duration, however, ultimately discharges this external capacitor, recycling slow turn-on upon release.

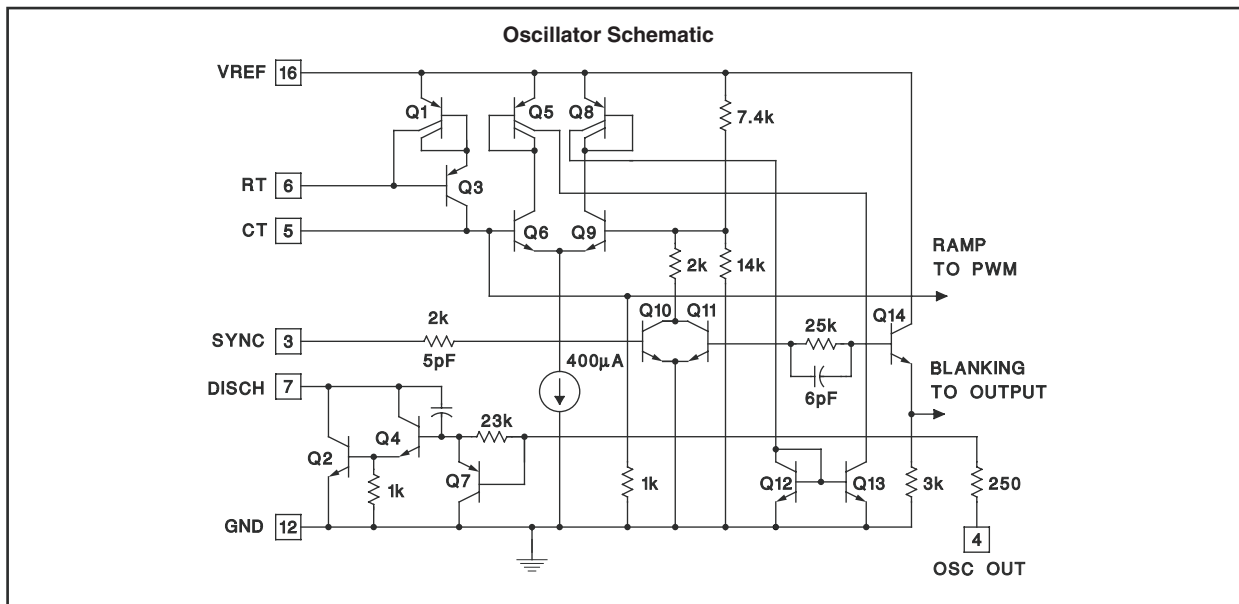

PRINCIPLES OF OPERATION AND TYPICAL CHARACTERISTICS (continued)

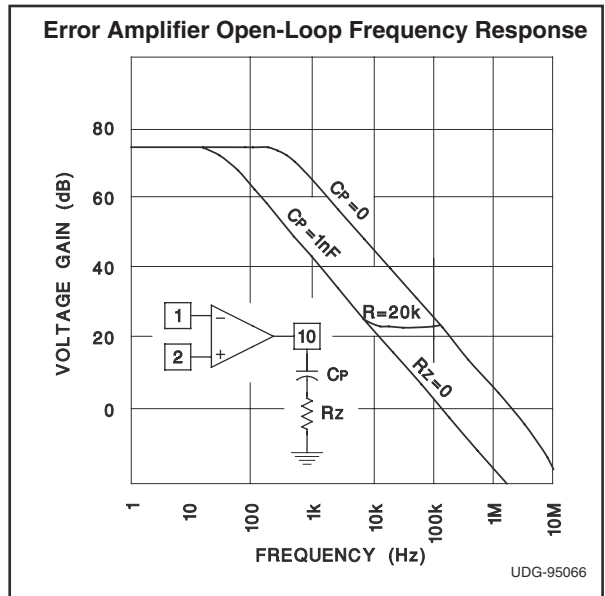
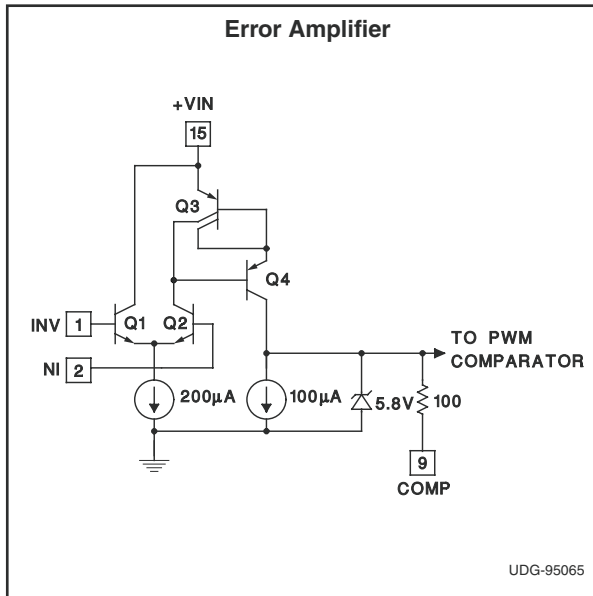
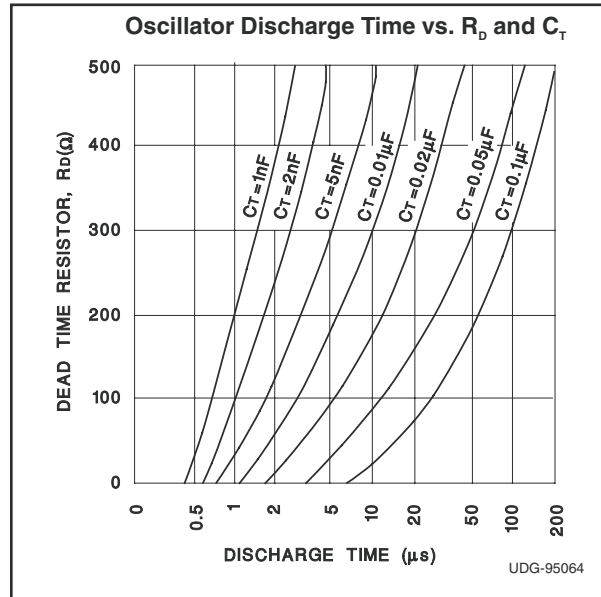
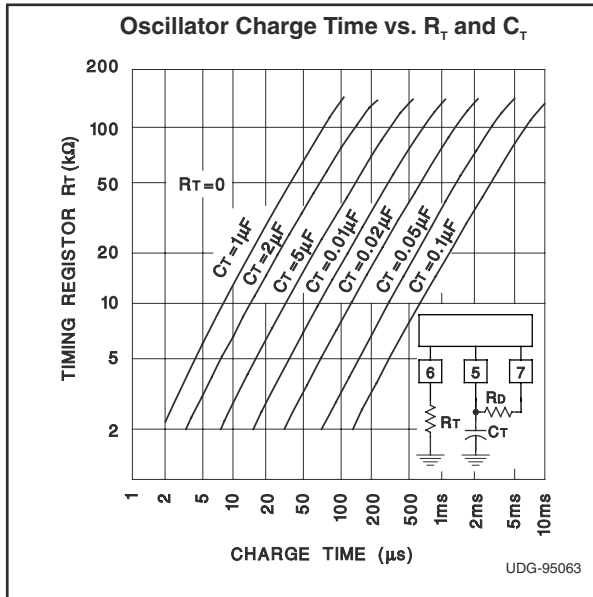



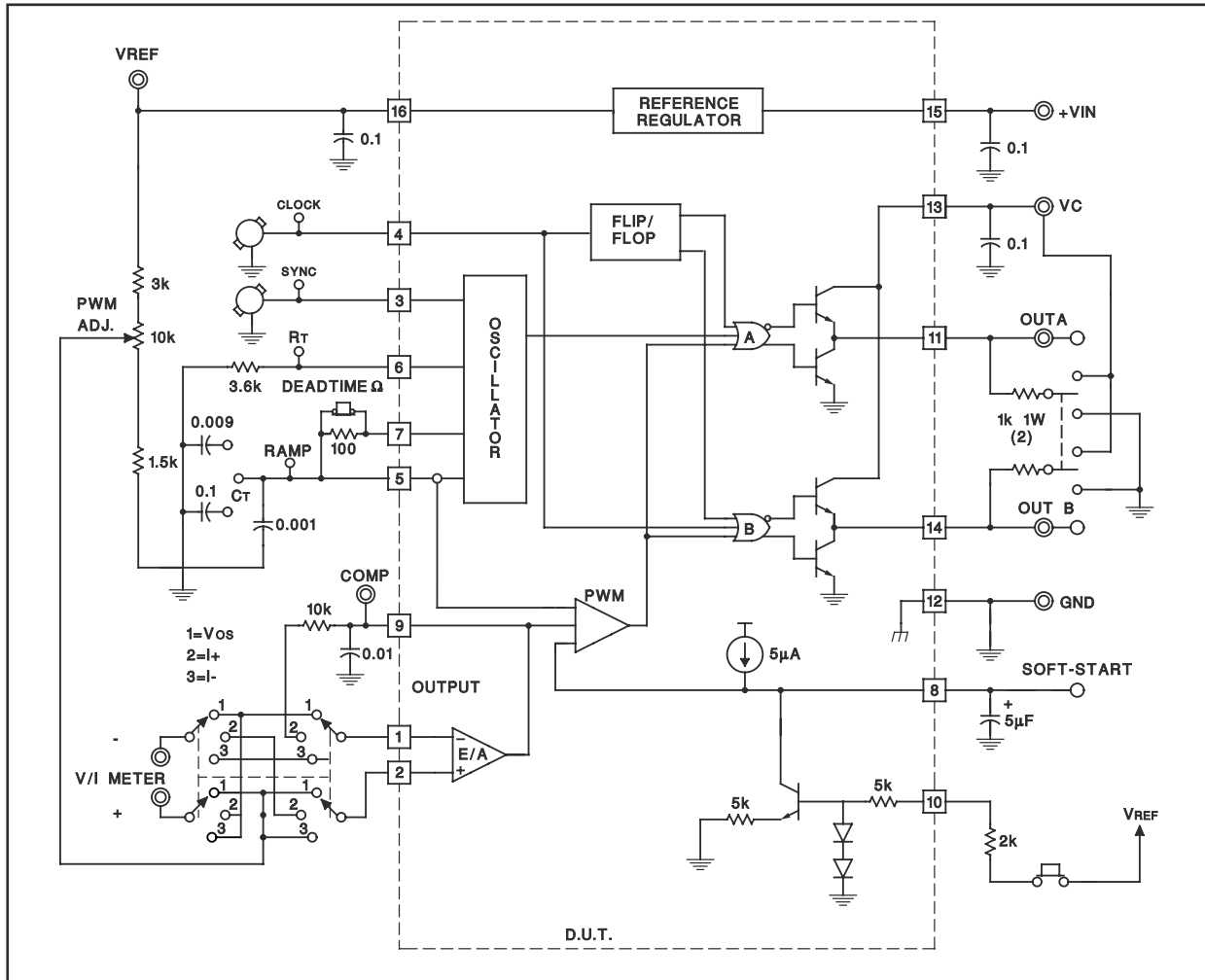

PRINCIPLES OF OPERATION AND TYPICAL CHARACTERISTICS (continued)

LAB TEST FIXTURE



**PACKAGING INFORMATION**

Orderable Device	Status (1)	Package Type	Package Drawing	Pins	Package Qty	Eco Plan (2)	Lead finish/ Ball material (6)	MSL Peak Temp (3)	Op Temp (°C)	Device Marking (4/5)	Samples
5962-8951105V2A	ACTIVE	LCCC	FK	20	1	Non-RoHS & Green	SNPB	N / A for Pkg Type	-55 to 125	5962- 8951105V2A UC1525BL QMLV	
5962-8951105VEA	ACTIVE	CDIP	J	16	1	Non-RoHS & Green	SNPB	N / A for Pkg Type	-55 to 125	5962-8951105VE A UC1525BJQMLV	
5962-8951106V2A	ACTIVE	LCCC	FK	20	1	Non-RoHS & Green	SNPB	N / A for Pkg Type	-55 to 125	5962- 8951106V2A UC1525BFK -SP	

(1) The marketing status values are defined as follows:

**ACTIVE:** Product device recommended for new designs.

**LIFEBUY:** TI has announced that the device will be discontinued, and a lifetime-buy period is in effect.

**NRND:** Not recommended for new designs. Device is in production to support existing customers, but TI does not recommend using this part in a new design.

**PREVIEW:** Device has been announced but is not in production. Samples may or may not be available.

**OBsolete:** TI has discontinued the production of the device.

(2) **RoHS:** TI defines "RoHS" to mean semiconductor products that are compliant with the current EU RoHS requirements for all 10 RoHS substances, including the requirement that RoHS substance do not exceed 0.1% by weight in homogeneous materials. Where designed to be soldered at high temperatures, "RoHS" products are suitable for use in specified lead-free processes. TI may reference these types of products as "Pb-Free".

**RoHS Exempt:** TI defines "RoHS Exempt" to mean products that contain lead but are compliant with EU RoHS pursuant to a specific EU RoHS exemption.

**Green:** TI defines "Green" to mean the content of Chlorine (Cl) and Bromine (Br) based flame retardants meet JS709B low halogen requirements of <=1000ppm threshold. Antimony trioxide based flame retardants must also meet the <=1000ppm threshold requirement.

(3) MSL, Peak Temp. - The Moisture Sensitivity Level rating according to the JEDEC industry standard classifications, and peak solder temperature.

(4) There may be additional marking, which relates to the logo, the lot trace code information, or the environmental category on the device.

(5) Multiple Device Markings will be inside parentheses. Only one Device Marking contained in parentheses and separated by a "-" will appear on a device. If a line is indented then it is a continuation of the previous line and the two combined represent the entire Device Marking for that device.

(6) Lead finish/Ball material - Orderable Devices may have multiple material finish options. Finish options are separated by a vertical ruled line. Lead finish/Ball material values may wrap to two lines if the finish value exceeds the maximum column width.

**Important Information and Disclaimer:** The information provided on this page represents TI's knowledge and belief as of the date that it is provided. TI bases its knowledge and belief on information provided by third parties, and makes no representation or warranty as to the accuracy of such information. Efforts are underway to better integrate information from third parties. TI has taken and continues to take reasonable steps to provide representative and accurate information but may not have conducted destructive testing or chemical analysis on incoming materials and chemicals. TI and TI suppliers consider certain information to be proprietary, and thus CAS numbers and other limited information may not be available for release.

In no event shall TI's liability arising out of such information exceed the total purchase price of the TI part(s) at issue in this document sold by TI to Customer on an annual basis.

**OTHER QUALIFIED VERSIONS OF UC1525B-SP :**

- Catalog: [UC1525B](#)

NOTE: Qualified Version Definitions:

- Catalog - TI's standard catalog product

FK (S-CQCC-N\*\*)

LEADLESS CERAMIC CHIP CARRIER

28 TERMINAL SHOWN



NO. OF TERMINALS **	A		B	
	MIN	MAX	MIN	MAX
20	0.342 (8,69)	0.358 (9,09)	0.307 (7,80)	0.358 (9,09)
28	0.442 (11,23)	0.458 (11,63)	0.406 (10,31)	0.458 (11,63)
44	0.640 (16,26)	0.660 (16,76)	0.495 (12,58)	0.560 (14,22)
52	0.740 (18,78)	0.761 (19,32)	0.495 (12,58)	0.560 (14,22)
68	0.938 (23,83)	0.962 (24,43)	0.850 (21,6)	0.858 (21,8)
84	1.141 (28,99)	1.165 (29,59)	1.047 (26,6)	1.063 (27,0)



4040140/D 01/11

- NOTES:
- All linear dimensions are in inches (millimeters).
  - This drawing is subject to change without notice.
  - This package can be hermetically sealed with a metal lid.
  - Falls within JEDEC MS-004

J (R-GDIP-T\*\*)

14 LEADS SHOWN

CERAMIC DUAL IN-LINE PACKAGE



DIM \ PINS **	14	16	18	20
A	0.300 (7,62) BSC	0.300 (7,62) BSC	0.300 (7,62) BSC	0.300 (7,62) BSC
B MAX	0.785 (19,94)	.840 (21,34)	0.960 (24,38)	1.060 (26,92)
B MIN	—	—	—	—
C MAX	0.300 (7,62)	0.300 (7,62)	0.310 (7,87)	0.300 (7,62)
C MIN	0.245 (6,22)	0.245 (6,22)	0.220 (5,59)	0.245 (6,22)



4040083/F 03/03

- NOTES:
- All linear dimensions are in inches (millimeters).
  - This drawing is subject to change without notice.
  - This package is hermetically sealed with a ceramic lid using glass frit.
  - Index point is provided on cap for terminal identification only on press ceramic glass frit seal only.
  - Falls within MIL STD 1835 GDIP1-T14, GDIP1-T16, GDIP1-T18 and GDIP1-T20.

## IMPORTANT NOTICE AND DISCLAIMER

TI PROVIDES TECHNICAL AND RELIABILITY DATA (INCLUDING DATASHEETS), DESIGN RESOURCES (INCLUDING REFERENCE DESIGNS), APPLICATION OR OTHER DESIGN ADVICE, WEB TOOLS, SAFETY INFORMATION, AND OTHER RESOURCES "AS IS" AND WITH ALL FAULTS, AND DISCLAIMS ALL WARRANTIES, EXPRESS AND IMPLIED, INCLUDING WITHOUT LIMITATION ANY IMPLIED WARRANTIES OF MERCHANTABILITY, FITNESS FOR A PARTICULAR PURPOSE OR NON-INFRINGEMENT OF THIRD PARTY INTELLECTUAL PROPERTY RIGHTS.

These resources are intended for skilled developers designing with TI products. You are solely responsible for (1) selecting the appropriate TI products for your application, (2) designing, validating and testing your application, and (3) ensuring your application meets applicable standards, and any other safety, security, or other requirements. These resources are subject to change without notice. TI grants you permission to use these resources only for development of an application that uses the TI products described in the resource. Other reproduction and display of these resources is prohibited. No license is granted to any other TI intellectual property right or to any third party intellectual property right. TI disclaims responsibility for, and you will fully indemnify TI and its representatives against, any claims, damages, costs, losses, and liabilities arising out of your use of these resources.

TI's products are provided subject to TI's Terms of Sale (<https://www.ti.com/legal/termsofsale.html>) or other applicable terms available either on [ti.com](https://www.ti.com) or provided in conjunction with such TI products. TI's provision of these resources does not expand or otherwise alter TI's applicable warranties or warranty disclaimers for TI products.

Mailing Address: Texas Instruments, Post Office Box 655303, Dallas, Texas 75265  
Copyright © 2021, Texas Instruments Incorporated