

## Rad-Tolerant Class-V, Precision Analog Controller

 Check for Samples: [UC19432-SP](#)

### FEATURES

- QML-V Qualified, SMD 5962-09233
- Rad Tolerant: 30 kRad(Si) TID <sup>(1)</sup>
  - TID Dose Rate = 10 mRad/sec
- Programmable Transconductance for Optimum Current Drive
- Accessible 1.3 V precision Reference
- Both Error Amplifier Inputs Available
- 0.7% Overall Reference Tolerance
- 0.4% Initial Accuracy
- 2.4-V to 24-V Operating Supply Voltage and User Programmable Reference
- Reference Accuracy Maintained for Entire Range of Supply Voltage

- Superior Accuracy and Easier Compensation for Optoisolator Application
- Low Quiescent Current (0.5 mA Typ)

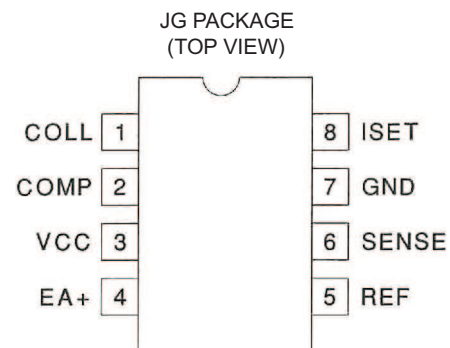

(1) Radiation tolerance is a typical value based upon initial device qualification. Radiation Lot Acceptance Testing is available - contact factory for details.

### DESCRIPTION

The UC19432 is an adjustable precision analog controller with 100-mA sink capability if the ISET pin is grounded. A resistor between ISET and ground will modify the transconductance while decreasing the maximum current sink. This will add further control in the optocoupler configuration. The trimmed precision reference along with the non-inverting error amplifier inputs are accessible for custom configuration. A sister device, the UC19431 adjustable shunt regulator, has an on-board resistor network providing six preprogrammed voltage levels, as well as external programming capability.

### ORDERING INFORMATION

T <sub>A</sub>	PACKAGE	ORDERABLE PART NUMBER	TOP-SIDE MARKING
-55°C to 125°C	CDIP-8	5962-0923301VPA	UC19432-SP



Please be aware that an important notice concerning availability, standard warranty, and use in critical applications of Texas Instruments semiconductor products and disclaimers thereto appears at the end of this data sheet.



## ELECTRICAL CHARACTERISTICS

over operating free-air temperature range, COLL output = 2.4 V to 24 V, VCC = 15 V, I<sub>COLL</sub> = 10 mA, T<sub>A</sub> = T<sub>J</sub> = –55°C to 125°C (unless otherwise noted).

PARAMETER	TEST CONDITIONS	MIN	TYP	MAX	UNIT
Reference voltage tolerance	T <sub>A</sub> = 25°C, V <sub>COLL</sub> = 5 V	1.295	1.3	1.305	V
Reference temperature tolerance	V <sub>COLL</sub> = 5 V	1.291	1.3	1.309	V
Reference line regulation	VCC = 2.4 V to 24 V, V <sub>COLL</sub> = 5 V		10	38	mV
Reference load regulation	I <sub>COLL</sub> = 10 mA TO 50 mA, V <sub>COLL</sub> = 5 V		10	38	mV
Reference sink current				10	μA
Reference source current		-10			μA
EA input bias current		-0.5	-0.2		μA
EA input offset voltage		-4		4	mV
EA+ Operational voltage limitations		0.9		1.6	V
EA output current sink (internally limited)		16			μA
EA output current source				-0.8	mA
Minimum operating current	VCC = 24 V, V <sub>COLL</sub> = 5 V		0.5	0.8	mA
Collector current limit <sup>(1)</sup>	V <sub>COLL</sub> = VCC = 24 V, Ref = 1.3 V, ISET = GND		130	155	mA
Collector saturation	I <sub>COLL</sub> = 20 mA	0.7	1.1	1.5	V
Transconductance (gm) <sup>(1) (2)</sup>	VCC = 2.4 V to 24 V, V <sub>COLL</sub> = 3 V, ISET = GND	-170	-140	-110	mS
Error amplifier AVOL		60	90		dB
Error amplifier GBW		1.5	3		MHz
Transconductance amplifier GBW			3		MHz

(1) Programmed transconductance and collector current limit equations are specified in the ISET pin description.

(2) Measured as ΔI<sub>COLL</sub>/ΔV<sub>COMP</sub> for I<sub>COLL</sub> = 5 mA to 20 mA.

## PIN DESCRIPTIONS

**COLL** The collector of the output transistor with a maximum voltage of 24 V. This pin is the output of the transconductance amplifier. The overall open loop voltage gain of the transconductance amplifier is gm x R<sub>L</sub>, where gm is designed to be –140 mS ±30 mS and R<sub>L</sub> represents the output load.

**COMP** The output of the error amplifier and the input to the transconductance amplifier. This pin is available to compensate the high frequency gain of the error amplifier. It is internally voltage limited to approximately 2 V.

**EA+** The non-inverting input to the error amplifier.

**GND** The reference and power ground for the device. The power ground of the output transistor is isolated on the chip from the substrate ground used to bias the remainder of the device.

**ISET** The current set pin for the transconductance amplifier. The transconductance will be –140 mS as specified in the electrical table if this pin is grounded. If a resistance, R<sub>L</sub>, is added to the ISET pin, the resulting new transconductance is calculated using [Equation 1](#). The maximum current will be approximated by [Equation 2](#).

$$gm = \frac{-0.714}{(5.1 \Omega + R_L)} \quad (1)$$

$$I_{MAX} = \frac{0.65 V}{5.1 \Omega + R_L} \quad (2)$$

**REF** The output of the trimmed precision reference. It can source or sink 10 μA and still maintain less than ±1% output variation.

**SENSE** The inverting terminal of the error amplifier used as both the voltage sense input to the error amplifier and its other compensation point. The error amplifier uses the SENSE input to compare against the 1.3-V on-chip reference.

The SENSE pin is also used as the under-voltage lockout (UVLO). It is intended to keep the chip from operating until the internal reference is properly biased. The threshold is approximately 1 V. It is important that once the UVLO is released, the error amplifier can drive the transconductance amplifier to stabilize the loop. If a capacitor is connected between the SENSE and COMP pins to create a pole, it will limit the slew rate of the error amplifier. To increase the bandwidth and ensure startup a low load current, it is recommended to create a zero along with the pole as shown in the UC19431 shunt regulator application. The error amplifier must slew 2 V to drive the transconductance amplifier initially on.

**VCC** The power connection for the device. The minimum to maximum operating voltage is 2.4 V to 24 V. The quiescent current is typically 0.5 mA.

## OVER-VOLTAGE COMPARATOR APPLICATION

The signal  $V_{IN}$  senses the input voltage. As long as the input voltage is less than 5.5 V, the output is equal to the voltage on  $V_{IN}$ . During this region of operation, the diode is reversed biased which keeps the EA+ pin at 1.3 V. When  $V_{IN}$  exceeds the over-voltage threshold of 5.5 V, the output is driven low. This forward biases the diode and creates hysteresis by changing the threshold to 4.5 V.

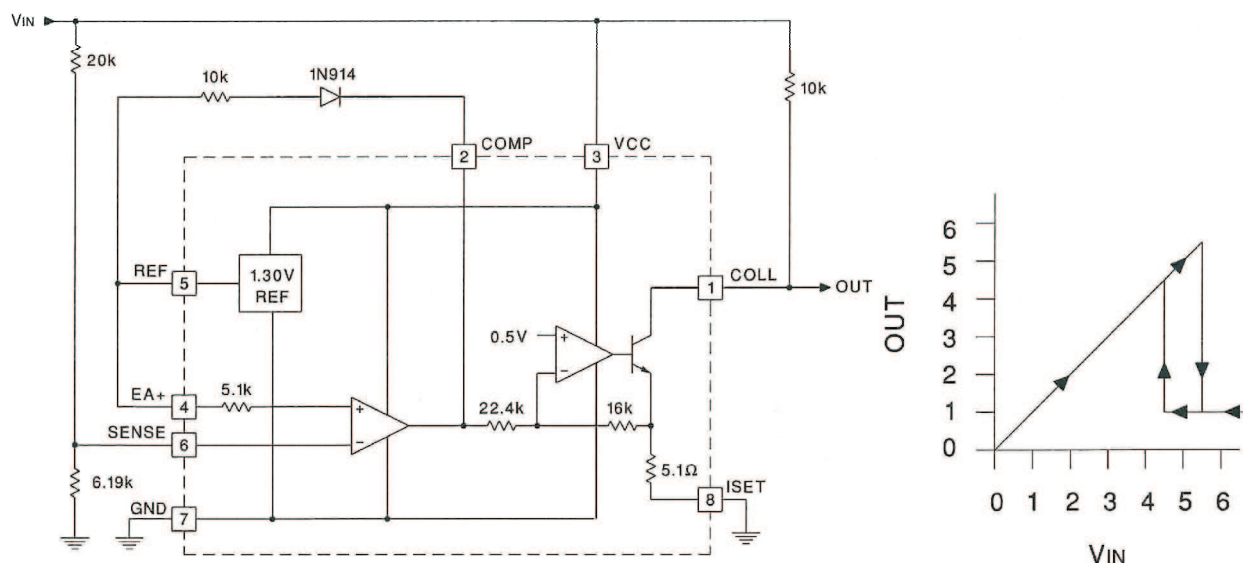

Figure 1. 5.5-V Over-Voltage Comparator With Hysteresis

## OPTOCOPLER APPLICATION

The optocoupler application shown in Figure 2 takes advantage of the accessible pins REF and ISET. The ISET pin has a 33-Ω resistor to ground that protects the optocoupler by limiting the current to about 16 mA. This also lowers the transconductance to approximately 19 mS. The ability to adjust the transconductance gives the designer further control of the loop gain. The REF pin is available to satisfy any high precision voltage requirements.

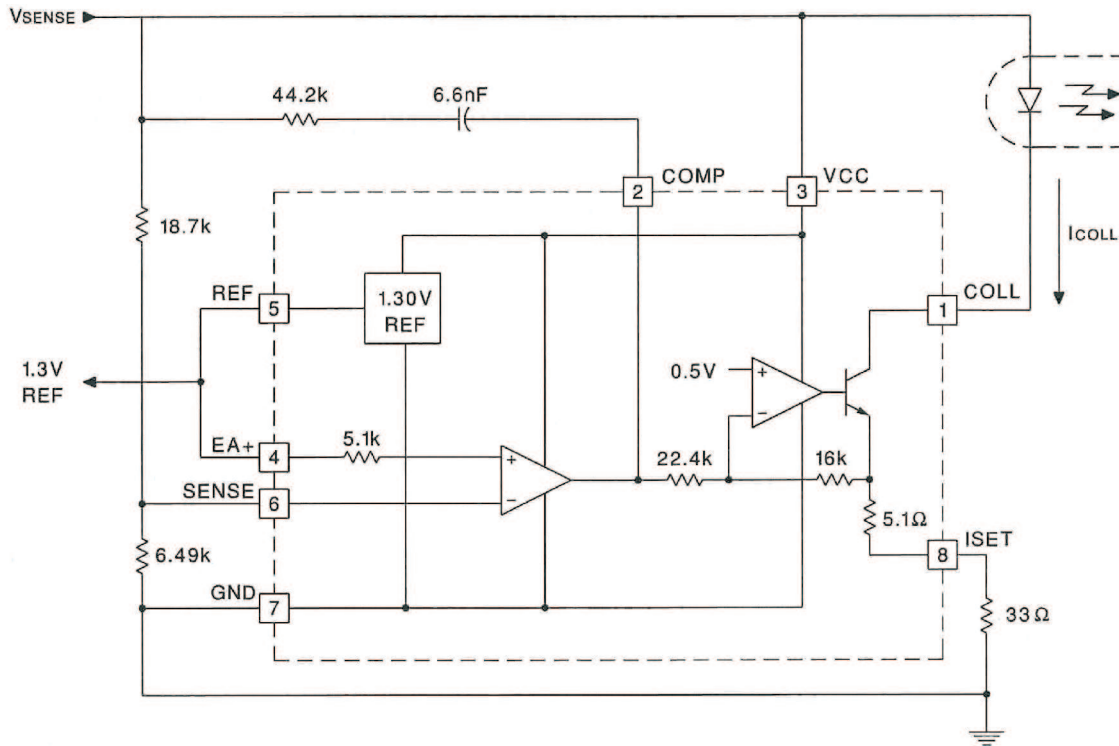

Figure 2. 5-V Optocoupler Application

**PACKAGING INFORMATION**

Orderable Device	Status (1)	Package Type	Package Drawing	Pins	Package Qty	Eco Plan (2)	Lead finish/ Ball material (6)	MSL Peak Temp (3)	Op Temp (°C)	Device Marking (4/5)	Samples
5962-0923301VPA	ACTIVE	CDIP	JG	8	1	Non-RoHS & Green	SNPB	N / A for Pkg Type	-55 to 125	0923301VPA UC19432-SP	<b>Samples</b>

(1) The marketing status values are defined as follows:

**ACTIVE:** Product device recommended for new designs.

**LIFEBUY:** TI has announced that the device will be discontinued, and a lifetime-buy period is in effect.

**NRND:** Not recommended for new designs. Device is in production to support existing customers, but TI does not recommend using this part in a new design.

**PREVIEW:** Device has been announced but is not in production. Samples may or may not be available.

**OBsolete:** TI has discontinued the production of the device.

(2) **RoHS:** TI defines "RoHS" to mean semiconductor products that are compliant with the current EU RoHS requirements for all 10 RoHS substances, including the requirement that RoHS substance do not exceed 0.1% by weight in homogeneous materials. Where designed to be soldered at high temperatures, "RoHS" products are suitable for use in specified lead-free processes. TI may reference these types of products as "Pb-Free".

**RoHS Exempt:** TI defines "RoHS Exempt" to mean products that contain lead but are compliant with EU RoHS pursuant to a specific EU RoHS exemption.

**Green:** TI defines "Green" to mean the content of Chlorine (Cl) and Bromine (Br) based flame retardants meet JS709B low halogen requirements of <=100ppm threshold. Antimony trioxide based flame retardants must also meet the <=1000ppm threshold requirement.

(3) MSL, Peak Temp. - The Moisture Sensitivity Level rating according to the JEDEC industry standard classifications, and peak solder temperature.

(4) There may be additional marking, which relates to the logo, the lot trace code information, or the environmental category on the device.

(5) Multiple Device Markings will be inside parentheses. Only one Device Marking contained in parentheses and separated by a "~" will appear on a device. If a line is indented then it is a continuation of the previous line and the two combined represent the entire Device Marking for that device.

(6) Lead finish/Ball material - Orderable Devices may have multiple material finish options. Finish options are separated by a vertical ruled line. Lead finish/Ball material values may wrap to two lines if the finish value exceeds the maximum column width.

**Important Information and Disclaimer:**The information provided on this page represents TI's knowledge and belief as of the date that it is provided. TI bases its knowledge and belief on information provided by third parties, and makes no representation or warranty as to the accuracy of such information. Efforts are underway to better integrate information from third parties. TI has taken and continues to take reasonable steps to provide representative and accurate information but may not have conducted destructive testing or chemical analysis on incoming materials and chemicals. TI and TI suppliers consider certain information to be proprietary, and thus CAS numbers and other limited information may not be available for release.

In no event shall TI's liability arising out of such information exceed the total purchase price of the TI part(s) at issue in this document sold by TI to Customer on an annual basis.

JG (R-GDIP-T8)

CERAMIC DUAL-IN-LINE



- NOTES: A. All linear dimensions are in inches (millimeters).  
 B. This drawing is subject to change without notice.  
 C. This package can be hermetically sealed with a ceramic lid using glass frit.  
 D. Index point is provided on cap for terminal identification.  
 E. Falls within MIL STD 1835 GDIP1-T8

## IMPORTANT NOTICE AND DISCLAIMER

TI PROVIDES TECHNICAL AND RELIABILITY DATA (INCLUDING DATASHEETS), DESIGN RESOURCES (INCLUDING REFERENCE DESIGNS), APPLICATION OR OTHER DESIGN ADVICE, WEB TOOLS, SAFETY INFORMATION, AND OTHER RESOURCES "AS IS" AND WITH ALL FAULTS, AND DISCLAIMS ALL WARRANTIES, EXPRESS AND IMPLIED, INCLUDING WITHOUT LIMITATION ANY IMPLIED WARRANTIES OF MERCHANTABILITY, FITNESS FOR A PARTICULAR PURPOSE OR NON-INFRINGEMENT OF THIRD PARTY INTELLECTUAL PROPERTY RIGHTS.

These resources are intended for skilled developers designing with TI products. You are solely responsible for (1) selecting the appropriate TI products for your application, (2) designing, validating and testing your application, and (3) ensuring your application meets applicable standards, and any other safety, security, or other requirements. These resources are subject to change without notice. TI grants you permission to use these resources only for development of an application that uses the TI products described in the resource. Other reproduction and display of these resources is prohibited. No license is granted to any other TI intellectual property right or to any third party intellectual property right. TI disclaims responsibility for, and you will fully indemnify TI and its representatives against, any claims, damages, costs, losses, and liabilities arising out of your use of these resources.

TI's products are provided subject to TI's Terms of Sale (<https://www.ti.com/legal/termsofsale.html>) or other applicable terms available either on [ti.com](https://www.ti.com) or provided in conjunction with such TI products. TI's provision of these resources does not expand or otherwise alter TI's applicable warranties or warranty disclaimers for TI products.

Mailing Address: Texas Instruments, Post Office Box 655303, Dallas, Texas 75265  
Copyright © 2021, Texas Instruments Incorporated